

# BUCKET ELEVATORS

## Installation and Operation Manual

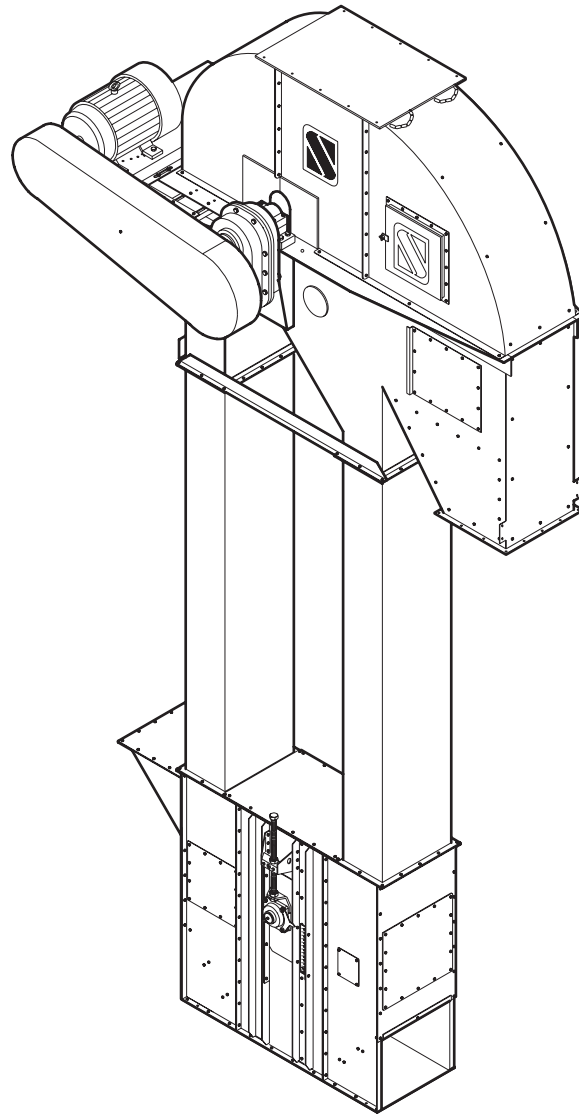

# SCHLAGEL

*Manufacturers of Innovative Materials Handling Equipment since 1957.*

491 North Emerson Street • Cambridge MN 55008-1316 U.S.A.  
Toll Free (800) 328-8002      FAX (763) 689-5310  
Local / International (763) 689-5991      EMAIL sales@schlagel.com  
**www.schlagel.com**

# TABLE OF CONTENTS

---

## SECTION 1 - GENERAL

<b>Pages</b>	1 . . . . .	Introduction
	2 . . . . .	Use of Manual
	2 . . . . .	Information Service
	3 . . . . .	Safety Code

## SECTION 2 - ASSEMBLY AND INSTALLATION

<b>Pages</b>	4 . . . . .	Uncrating and Inspection
	4 . . . . .	Electrical Requirements
	5-7 . . . . .	Assembly, Basic Components
	8 . . . . .	Cups & Belt
	9-10 . . . . .	Belt Splicing Methods
	11 . . . . .	Cutting Belt Square
	12-14 . . . . .	Final Adjustments
	15 . . . . .	Safety Devices
	15 . . . . .	Ladder, Cage and Platform
	15 . . . . .	Explosion Panels
	15 . . . . .	Maintenance
	16 . . . . .	Notes

## SECTION 3 - TROUBLE SHOOTING

<b>Pages</b>	17-18 . . . . .	Problem / Remedy
--------------	-----------------	------------------

## INTRODUCTION

---

This Bucket Elevator Manual will confine its scope to general information on a "standard leg installation." The variety of leg sizes, up to 60,000 BPH, would make a single, complete, installation manual impossible to compile. In addition, the location of the leg installation such as inside a leg well, in a tower system supported alongside another structure or a guyed, free-standing system, prohibit such a manual. Further, site preparation, erecting devices such as hoists or cranes (or the lack of them), and, most importantly, a contractor's experience and techniques, will necessarily limit this manual to an overview of some common approaches.

The most important consideration during the installation process is following the various manufacturer's instructions for the many components that make up the bucket elevator. If the installer is unsure about any phase of the installation, please contact us for assistance. We can answer most of your questions or suggest professional services to help you complete the installation.

**USE OF MANUAL**

This manual provides installation, operation, service recommendations and replacement parts identification for Schlagel Bucket Elevators.

Each section of the manual is fully illustrated for fast, accurate reference. **It is highly recommended that this manual be read thoroughly by those who are responsible for the installation, operation and maintenance of this elevator.** Refer to the Table of Contents, Page 1 for the location of specific information.

As new information and equipment become available, service and parts bulletins will be issued by Schlagel, Inc. So that they will be readily available for reference, all bulletins should be inserted with this manual. This manual covers standard elevator equipment only. For any items or special equipment not covered in this manual, please consult our service department for recommendations or instructions regarding this equipment.

**INFORMATION SERVICE**

Our service department will provide consultation on installation, operation and maintenance at no cost to you. Also, information from you, regarding encountered operation or service problems that are not covered in this manual will be greatly appreciated.

Contact Schlagel, Inc. for information on adding new equipment to your system or changing your installation such as: Lengthening or shortening trunking, horsepower and speed requirements, etc.

Schlagel, Inc. keeps a complete record of each customer's order. However, valuable time can be saved if the following information is provided with your inquiry.

It is suggested that you obtain the **model number** and **serial number** from the packing slip, or on the Bucket Elevator SN tag, and enter it below for **each** bucket elevator in your system.

Date of Purchase: \_\_\_\_\_

Purchased from: \_\_\_\_\_

Installed by: \_\_\_\_\_ Date: \_\_\_\_\_

Model Number:	Serial Number:
_____	_____
_____	_____
_____	_____

Email or Call: Schlagel, Inc.  
 491 North Emerson Street  
 Cambridge, MN 55008  
 (763) 689-5991 or 1-800-328-8002  
 sales@schlagel.com

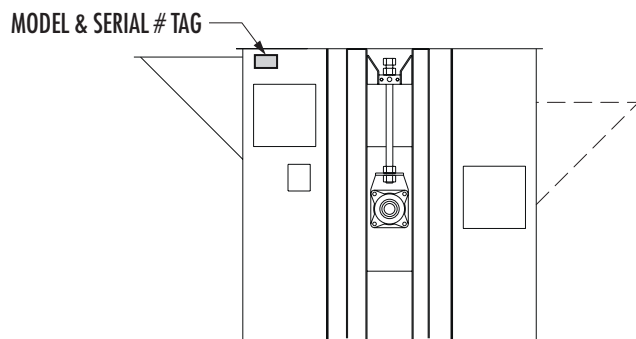
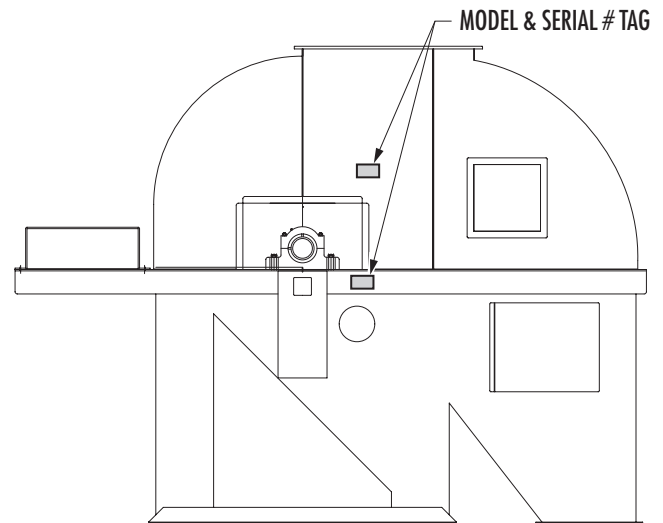

SAFETY CODE

**! WARNING !**

The icon shown below was proposed as a safety alert symbol by the Farm and Industrial Equipment Institute (FIEI) and approved by the American Society of Automotive Engineers (ASAE) and others for the purpose of calling attention to safety precautions which if not heeded might lead to bodily injury.

*Please read instructions carefully and follow the instructions exactly wherever this symbol appears in the manual.*

**!**



LOOK FOR THESE SAFETY LABELS

**! WARNING !**



**EXPOSED BELT CHAIN & MOVING PARTS CAN CAUSE SEVERE INJURY**

**LOCK OUT POWER BEFORE REMOVING GUARD**

**! WARNING !**



**Exposed buckets and moving parts can cause severe injury**

**LOCK OUT POWER before removing cover or servicing**

**! DANGER !**



**EXPLOSION RELEASE WILL CAUSE SEVERE INJURY OR DEATH**

**AVOID AREA AROUND EXPLOSION VENT DURING OPERATION**

## UNCRATING AND INSPECTION

All parts have been carefully checked before shipment from our factory. Carefully inspect all parts for damage that may have occurred during shipment. Look for dents in trunking sections and bent or misaligned flanges or shafts. If these are not corrected, one can expect continuing problems and reduced life of the bucket elevator. Check to make sure that all items listed in your Packing List are included.

If damages or shortages are noted, have the transportation company's representative note this on the Bill of Lading and notify Schlagel, Inc. Locate the model and serial number on the bucket elevator drive side and reference the missing or damaged part from the packing list. Forward this information along with the shipping date so that we may expedite the replacement parts.

### IMPORTANT

*All claims for shipping damages must be noted by the consignee at the time of delivery and filed with the transportation company.*

### WARNING

The lifting bracket located in the top of the head section cover is for removing cover from head section only **"Do not attempt to lift entire head section with this cover lifting bracket"**

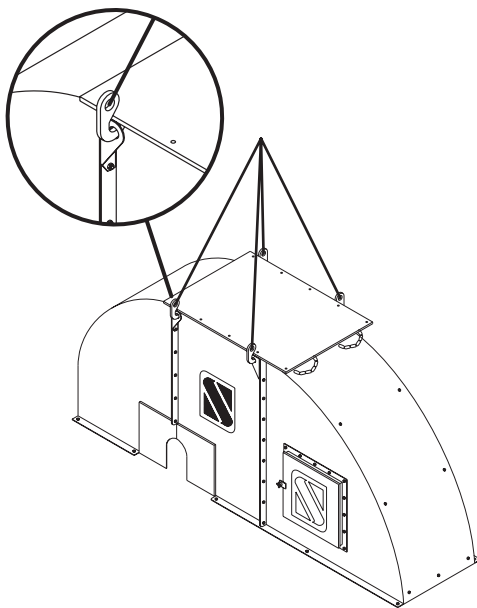

## ELECTRICAL REQUIREMENTS

All electrical connections should be made by a qualified electrician. Check local codes before installation. A lockable external line disconnect switch, in compliance with local codes, must be provided and located as close as possible to the bucket elevator.

When the Bucket Elevator is connected with other machinery, electrical interlock priorities should be maintained so that if any other equipment fails, all preceding equipment would stop.

### WARNING

Before removing Bucket Elevators covers or drive guards to attempt any repairs or adjustments, shut off and lock the line disconnect switch.

### ASSEMBLY OF BASIC COMPONENTS

Various combinations of components are shown in Figure 1. Your leg will differ from this depending on the model and options ordered. The Bill of Materials will list the components you have received and indicate what fasteners are required for assembly. The following instructions refer to the assembly of a typical leg similar to that shown in Figure 1.

The boot section should be fastened securely on a suitable foundation and shimmed to level in all directions. In some cases the boot should sit on properly sized channels to keep water from infiltrating the system. The boot pockets should be attached at the level recommended by us in our catalog. If there is a question regarding proper feeding on the up or downside of the boot, it must be resolved at this time.

The first few sections of trunking that attach to the boot need special consideration. The best position for the access door and inspection port should be determined and located accordingly. Note that the inspection port is located on the upside and may be re-assembled to locate it at positions other than as shipped.

Trunking is fabricated in 10' standard lengths and is precisely jig welded to insure a straight leg. Check each flange as it is assembled for damage and straighten or replace if necessary. The tie braces should be studied so their assembly corresponds with ladder, cage, and rest platforms, if used. Tighten bolts evenly, making sure the sections are not twisted. This joint must be smooth inside so a bucket cannot catch on it. Standard trunking sections are symmetrical and therefore can be placed without regard to direction. The short section is usually placed just below the head section rather than at the boot or center of the leg. Plumb the trunking in all directions as it is assembled and check it again after the installation is complete.

The head section must support the dynamic forces imposed by the drive, discharging buckets, attached spouts, service platform, wind and numerous other stresses. Proper guying or bracing to other structures is imperative. Besides the obvious catastrophic failure and collapse of the leg if not properly braced, less obvious and troublesome maintenance and/or operational "bugs" are sure to plague its operation.

It is necessary to have the head shaft perfectly level so the belt will track properly on the head pulley. Place shims between the bearings and bridge trees if necessary. The bearing adjustment blocks located on the end of each bearing and the jack bolt located under bearing and bridge tree will assist in truing up pulley.

### DRIVES

It is the responsibility of the installing contractor to assemble the drive mechanism so that it will conform to or exceed all safety and electrical codes, regardless if the drive is furnished with the leg or whether it is supplied by the contractor or user. In all cases, the installer must see to it that all manufacturer's instructions for installation and start up preparation have been followed. In those instances where we do not supply the drive, please consult with us for horsepower and speed requirements.

A common drive for legs is the shaft-mounted type. This drive is often used because the reducer is mounted directly on the head shaft, eliminating high torque final chain drives. A torque arm is used to resist drive rotation and provide belt adjustment. We can provide the brackets necessary for the proper attachment of these components. Follow the drive manufacturer's instructions if these brackets are not included.

If a backstop is required, care must be taken to turn the drive in the proper rotation by hand to see that it has been installed properly.



#### WARNING



After the motor is mounted but before the belts are attached, run the motor to check rotation before attaching the drive belt, coupling or chain.

Figure 1

**INSTALLATION**

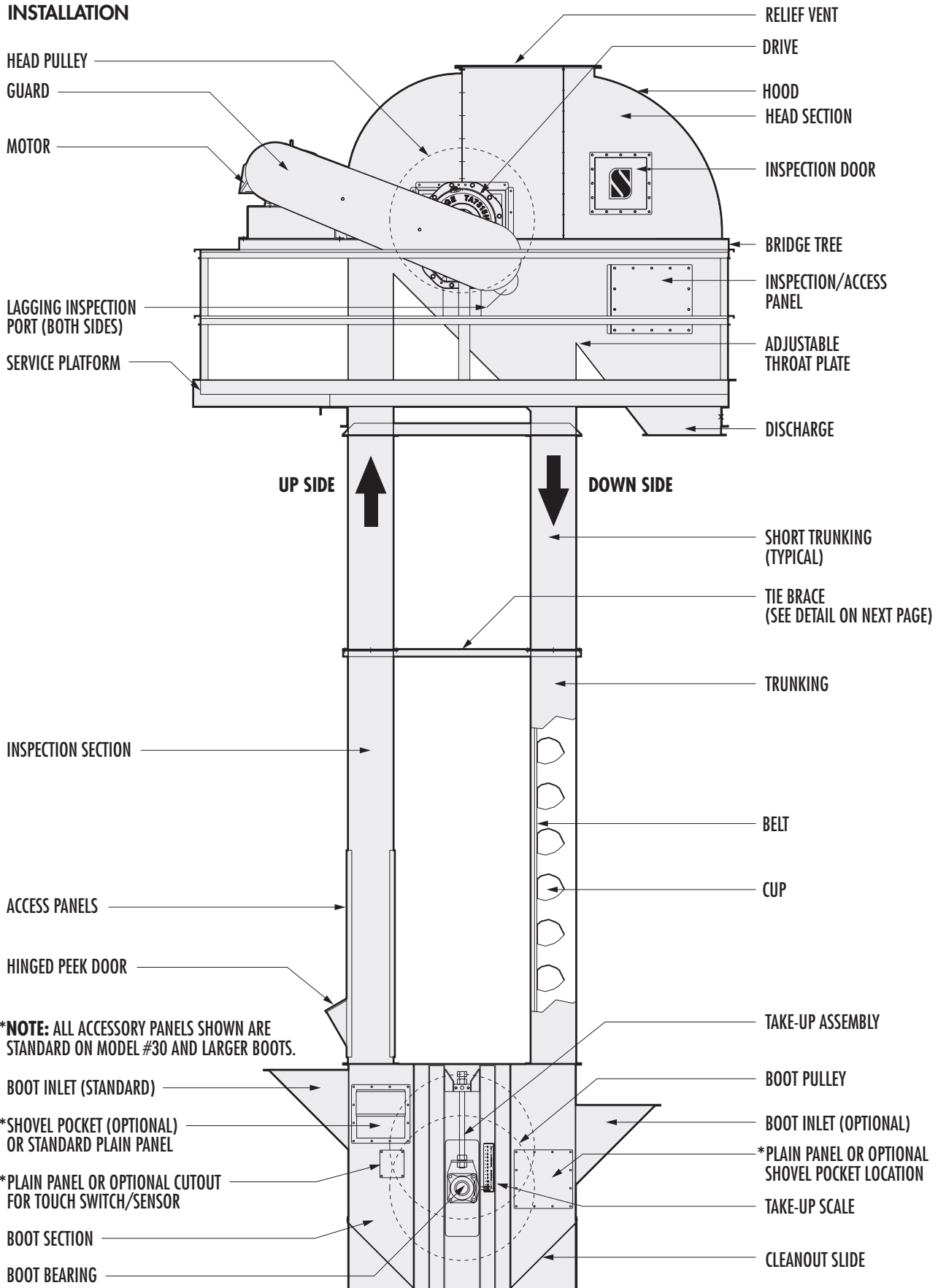

## SECTION 2 - ASSEMBLY AND INSTALLATION

**NOTE:** FOR LADDER AND CAGE ASSEMBLY INSTRUCTIONS PLEASE SEE PLATFORMS ASSEMBLY MANUAL.

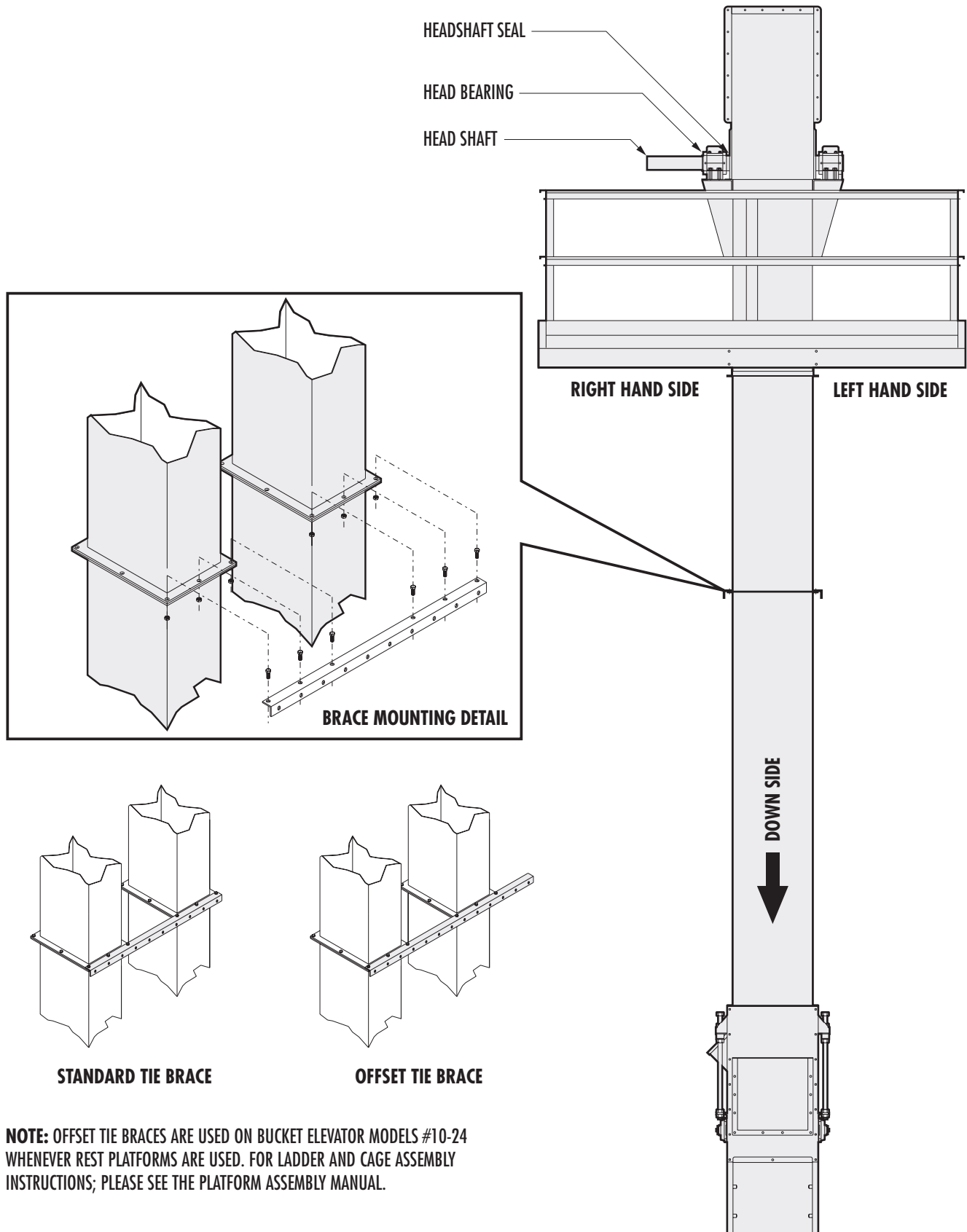

**NOTE:** OFFSET TIE BRACES ARE USED ON BUCKET ELEVATOR MODELS #10-24 WHENEVER REST PLATFORMS ARE USED. FOR LADDER AND CAGE ASSEMBLY INSTRUCTIONS; PLEASE SEE THE PLATFORM ASSEMBLY MANUAL.



**CUPS**

Cups are attached using the hardware supplied. Be sure to tighten the nuts adequately to ensure a good "set" of the head into the back of the belt. The head of the elevator bolt should fit just below the surface of the back of the belt. **Be careful not to create a deformation or bulge in the back of the belt by over tightening.**

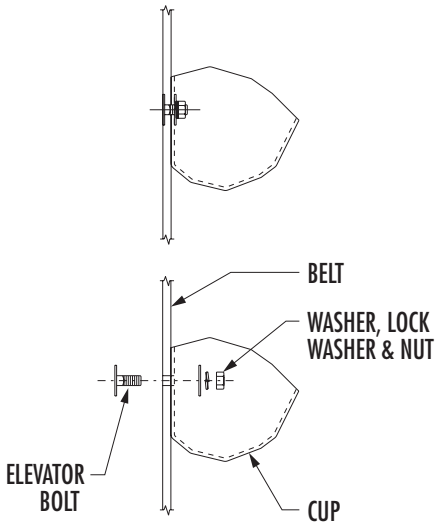

**Recommended Maximum Torque for Elevator Bolts**

	In./lbs.	Ft./lbs
1/4" diameter	72	6
5/16" diameter	132	11
3/8" diameter	240	20

The listed max torque is an estimate for mild steel, zinc plated and stainless steel Norway #1 style bolts using flat washer, lock washer, and hex nut. The figures listed in the chart above are guidelines only. These figures may be higher than necessary for the proper seating of the elevator bolt.

**Always follow cup manufacturer's recommendation for tightening of the bolts.**

After installing the cups according to manufacturer's instructions run the Bucket Elevator for a few hours. Then retighten the bolts. Inspection of the cup bolts should be part of a maintenance program to ensure all cups are properly fastened.

**BELT**

The belt is usually pulled through the access door on the upleg, around the head pulley, boot pulley and back to the door where it is spliced. The lap splice is standard and is used unless another type has been specifically ordered. See Figure 2. Additional belt length has been furnished so that six cups may be bolted over the lap. Long cup bolts called "splice bolts" on the Bill of Materials are included for this lap area. The proper direction for the lap is shown in Figure 2.

With the boot pulley in the highest take-up position, let the belt hang, with the cups attached, for 24 hours if possible. This will remove almost all of the initial stretch and will require less adjustment during the break-in period.

Figure 2

**OVERLAP BELT SPLICE**

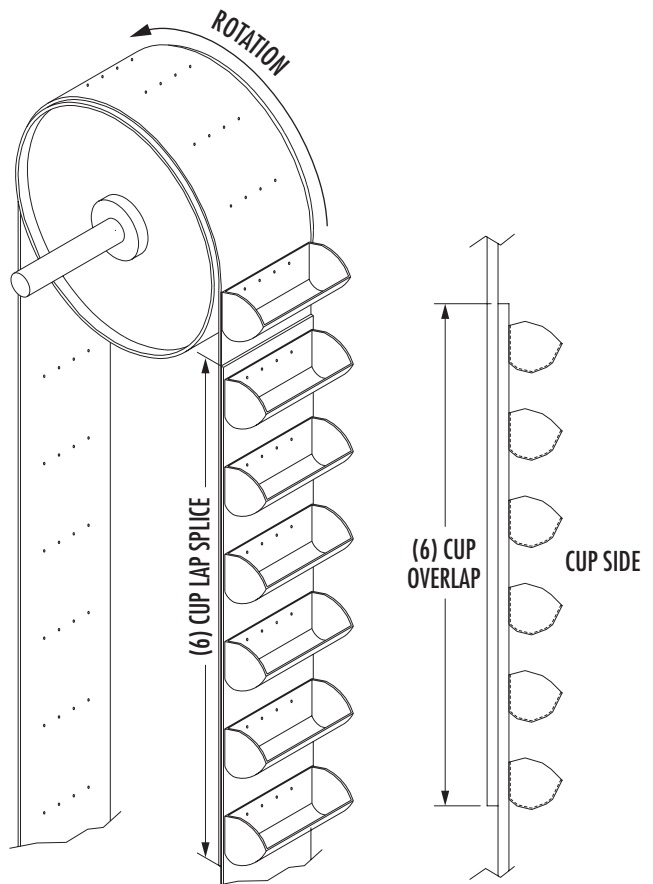

SPLICING METHODS

BUTT STRAP SPLICE

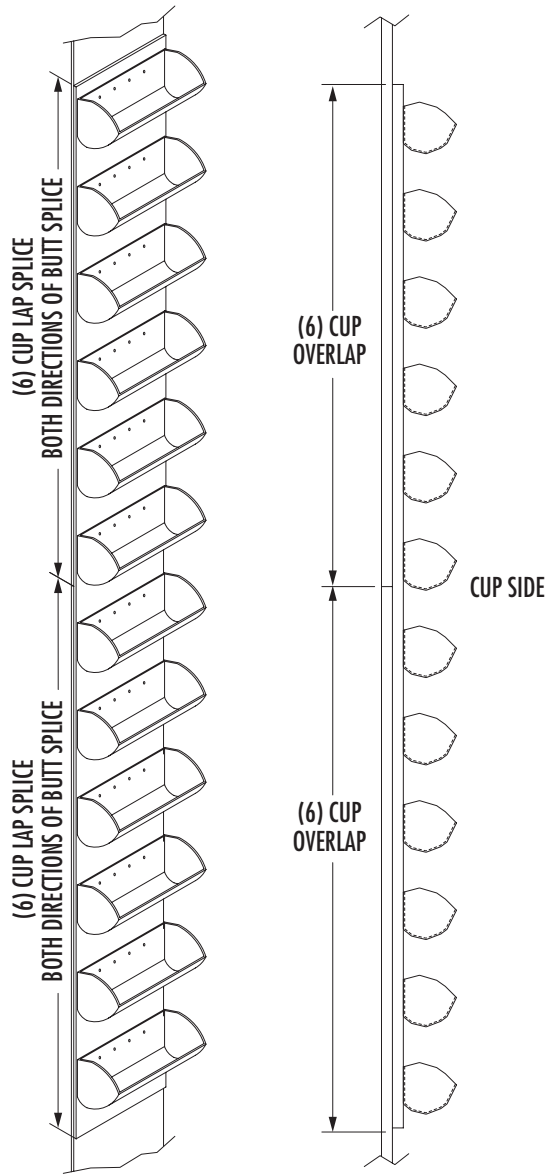

BAR CLAMP BELT SPLICE

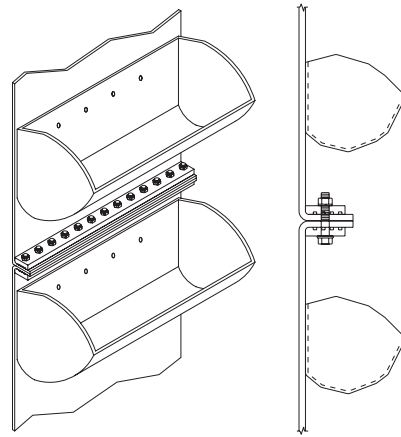

MAXI-SPLICE STYLE-AB or TAPCO BELT SPLICE STYLE 'NS'

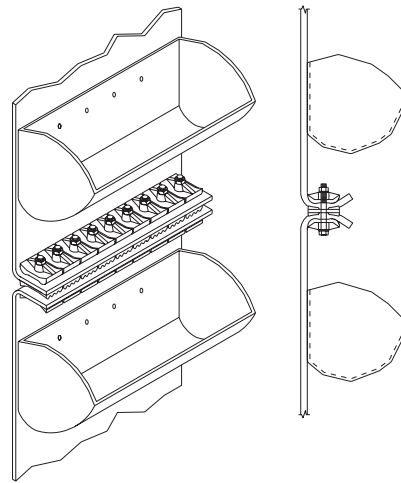

### BELT SPLICE FASTENER INSTALLATION INSTRUCTIONS (MAXI-SPLICE STYLE-AB or TAPCO SPLICE STYLE 'NS')

1. First ensure the belt ends are square and even. (See page 11) If using the splice template tape, apply the tape to mark the punching. Be sure to apply the tape squarely on the belt ends; then proceed to step 4. If you are not using the tape, go to step 2.
2. Draw a line approximately 4-1/4" from the belt end to use as the center line for hole punching. Proper installation for even width belts will begin just inside the belt edge. **See splice manufacturer's instruction sheet for details.** Odd belt widths require installation 1/2" from the belt edge.
3. Use the clamp belt fastener as a template to mark the hole locations for punching. After marking the first hole, move over 2" and mark each consecutive hole.
4. Punch both belt ends for 1/2" diameter bolts.
5. The two end plates and center plate are used for firm belt gripping. The plates have two gripping areas – the slotted gripping area is mounted toward the face of the belt and is followed by a series of gripping teeth. These teeth are always mounted toward the tail of the belt. The center plate of the Maxi-Splice is symmetrical and cannot be improperly installed. **Be sure the gripping teeth are always toward tail end of belt.**
6. **IMPORTANT:** We have supplied a 1/2" diameter x 4-1/2", Grade 5 bolt and nylon locking nut. The bolts must be torqued properly for the fastener to effectively clamp.

The suggested torque for the Maxi-Splice is 100 foot pounds with a minimum requirement of 75 foot pounds for belts up to and including 600 PIW – belts greater than 600 up to 800 PIW tensile require 100 foot pounds of torque.

The torque requirement for the Tapco-Splice is 75 foot pounds for all belts up to 800 PIW.

**Always follow the splice manufacturer's torque specs. See the instruction sheet supplied with splice for details.**

7. Run the belt for thirty minutes; stop the leg and re-torque the bolts.
8. When reinstalling the clamp belt fastener always use new Nylock nuts.

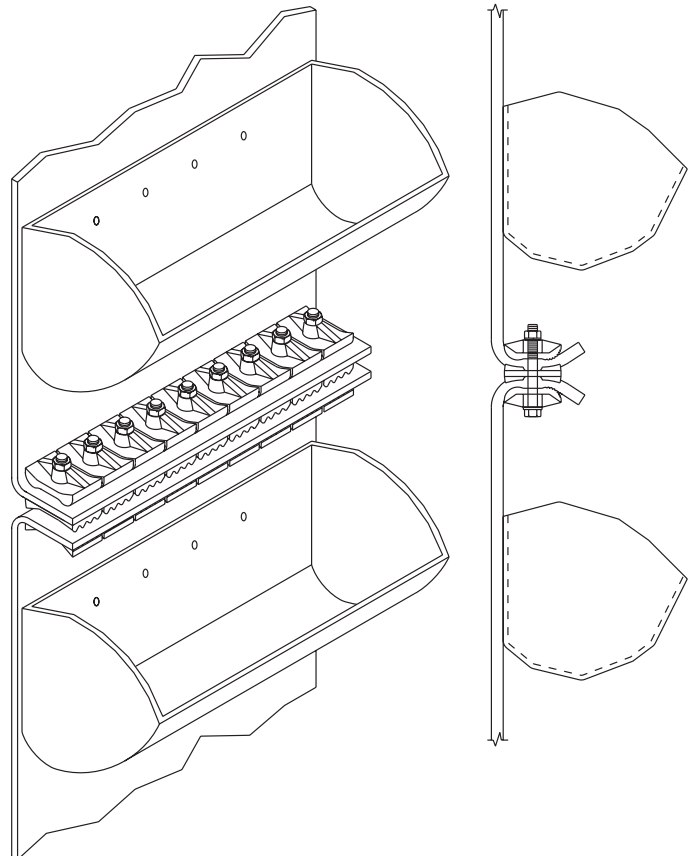

**INSTRUCTIONS FOR CUTTING BELT SQUARE**

**The following steps will help ensure that your belt is properly squared.**

1. Prior to any work on your conveyors, make certain that the power has been turned off and the belt is "locked out." Follow other safety precautions outlined in the operator's manual.
2. Mark the actual center points in belt width at intervals of 3 to 5 feet, for a distance back from the intended splice area of 15 to 20 feet.
3. Using either a steel rule or chalk line, mark the average center line through the points measured from Step 2.
4. Using a square, draw a line perpendicular to your average center line across the belt width.
5. For even greater accuracy in preparing your squaring line and with belts with worn edges, after completion of step three, mark two lines (B & C) equal distance from the center line in the area where you are going to install the splice, running parallel to the center line.

6. Measure back from the intended splice area a distance equal to approximately three times the belt width and drive a nail or awl at this point on the center line. Using the nail or awl as a pivot point, swing an arc, making the belt across the full width.
7. Where this arc intersects the two smaller lines marked parallel to the average belt center, align a steel rule through these points. The resulting line is the true square.
8. Mark this line and cut your belt at this line using a sharp knife or, preferably a belt cutter.

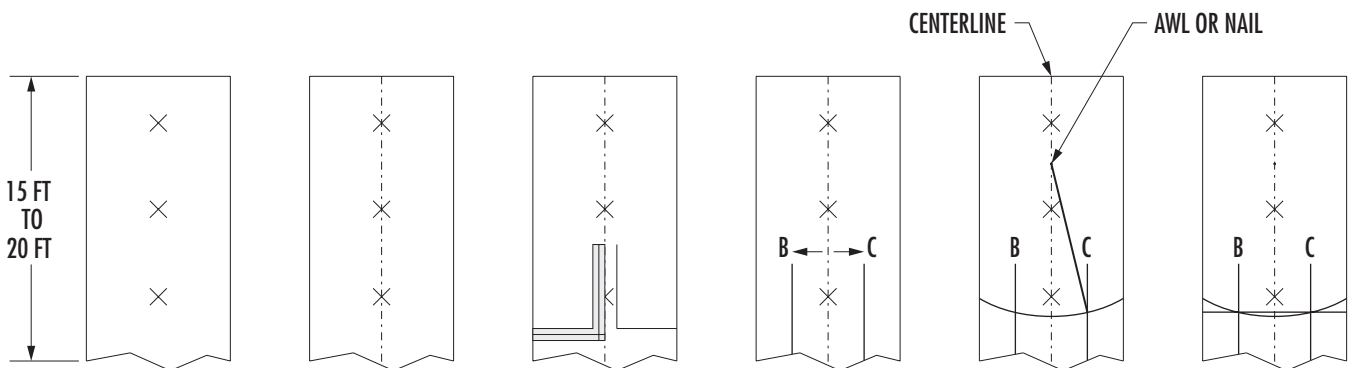

## FINAL ADJUSTMENTS

### ⚠ WARNING ⚠

Before removing Bucket Elevators covers or drive guards to attempt any repairs or adjustments, shut off and lock the line disconnect switch. For electrical information on optional equipment, see appropriate section or specific engineering drawings in the back of this manual.

### ⚠ WARNING ⚠

Before running the elevator make sure all guards are in place, inspection doors are closed, and safety devices are connected and operational.

### ADJUSTABLE THROAT PLATE w/ URETHANE WIPER

Adjust the throat plate with urethane wiper in the head discharge so there is about 1/8" clearance between it and the edge of the cups on the lap splice.

**Make certain to make this adjustment on the lap splice to avoid damaging cups or the wiper assembly.** The adjustment can be made by loosening the flange nuts located on the underside of the head discharge.

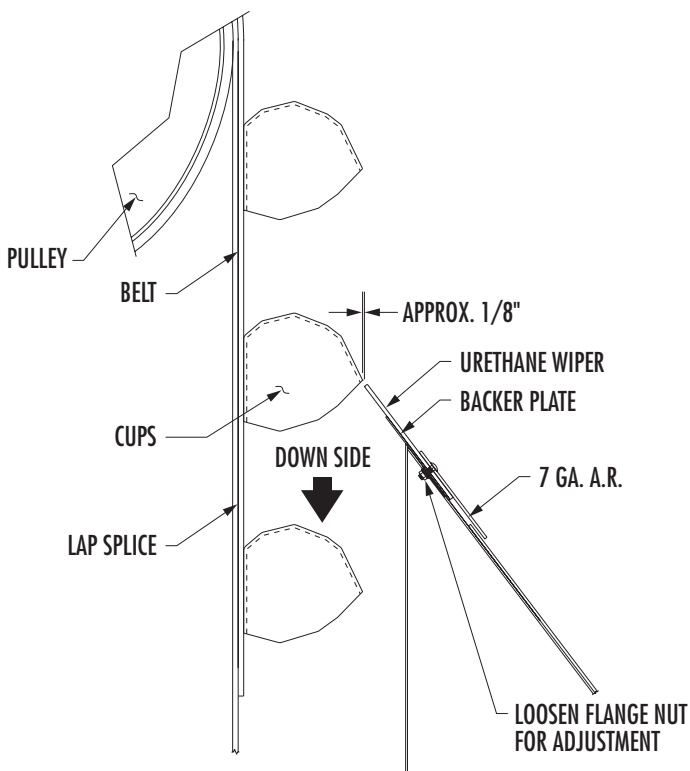

### TIGHTEN THE TAKE-UPS

Tighten the take-ups on the boot evenly and then make an initial tracking adjustment while running empty. The leg should run quietly, without the belt or cups touching any part of the housing.

The final tensioning of the belt is done under load. The boot shaft should always be turning and the belt always tracking whether running full or empty.

**NOTE:** See guidelines on page 14.

Many factors affect the maximum belt tension. Such determining factors are belt PIW, boot pulley components, head pulley components and lagging type, material, capacity, discharge height, and others. The chart on page 14 shows the maximum take-up bolt torque that can be applied. **Do NOT under any circumstance exceed the maximum torque listed in the chart.**

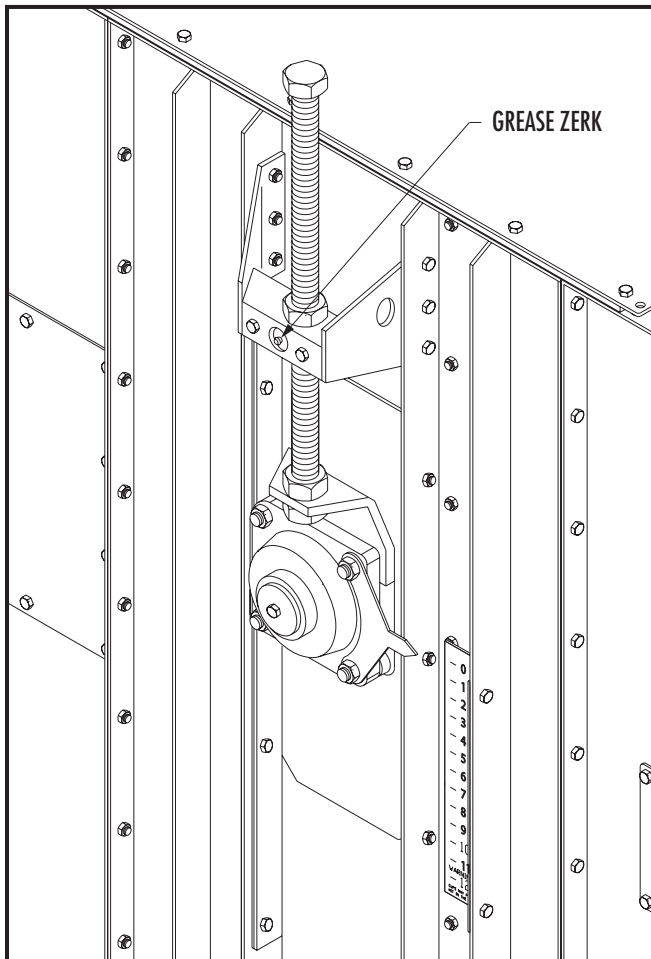

Most installations will require much less than the maximums shown here. Ideal belt tension is the least amount of pressure applied to the boot pulley take-ups, to keep the belt from slipping on the head pulley while the bucket elevator is fully loaded. After initial installation and adjustment we recommend the following guidelines for adjustment.

- Lubricate the take-up screws.
- Snug the take-up screws until the obvious belt slack is removed.
- Start the empty leg and adjust the screws to center the belt.
- Begin feeding material slowly to the leg. As the load is increased it may be necessary to adjust the take-ups equally, in small amounts to keep the belt centered. The weight of the loaded material will stretch the belt and require more tension to keep the belt from slipping on the head pulley. It is likely the torque on the take-up screw will only be a fraction of the maximum shown in the chart.
- The boot take-up should be checked often, especially after installing a new belt.

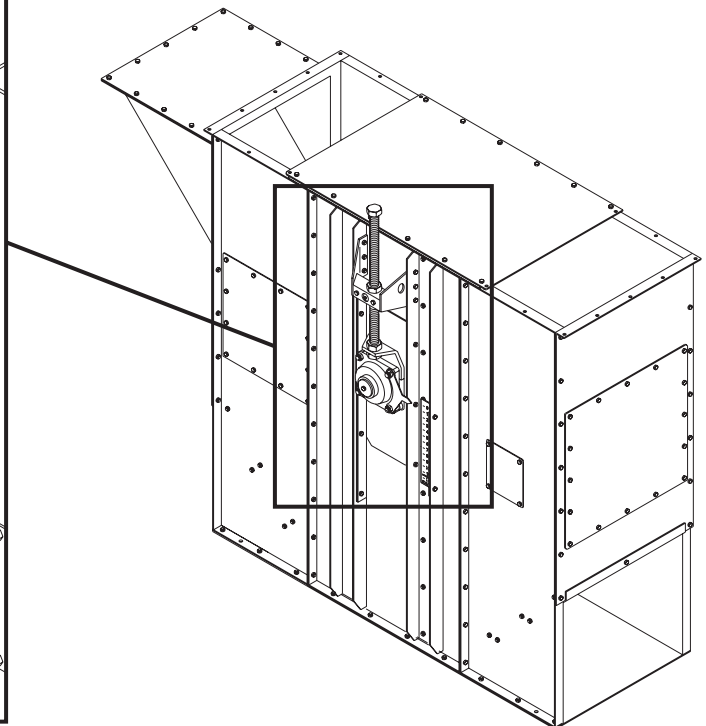

GUIDELINES FOR *MAXIMUM* TORQUE ON EACH THREADED TAKEUP ROD ON BOOT.

DISCHARGE HEIGHT	MODEL 664	MODEL 1075	MODEL 1695	MODEL 20116	MODEL 24116	MODEL 30147	MODEL 36147	MODEL 42168	MODEL 42208	MODEL 42208LP	MODEL 48208	MODEL 48208LP
20'	10	10	10	10	10	10	20	20	20	20	20	20
30'	10	10	10	10	10	10	20	20	20	20	20	20
40'	10	10	10	10	10	10	20	20	20	25	20	20
50'	10	10	10	10	10	10	20	20	23	30	20	30
60'	10	10	10	10	10	15	20	20	30	35	25	30
70'	15	10	10	10	10	15	20	25	30	40	30	35
80'	----	10	10	10	10	15	20	30	40	45	30	40
90'	----	15	10	10	10	20	20	35	40	55	35	45
100'	----	15	10	15	10	20	20	35	45	60	40	50
110'	----	----	10	15	10	25	25	40	50	65	45	60
120'	----	----	10	15	15	25	25	45	55	70	50	60
130'	----	----	10	15	15	30	30	50	60	75	50	70
140'	----	----	15	20	15	30	30	50	65	85	55	70
150'	----	----	15	20	15	30	30	55	70	90	60	80
160'	----	----	15	20	20	35	35	60	75	95	65	80
170'	----	----	----	20	20	35	35	60	80	100	70	90
180'	----	----	----	25	20	40	40	65	85	105	75	95
190'	----	----	----	----	20	40	40	70	90	110	75	100
200'	----	----	----	----	25	45	45	75	90	120	80	100
210'	----	----	----	----	----	45	45	75	95	125	85	110
220'	----	----	----	----	----	45	50	80	100	130	90	115
230'	----	----	----	----	----	50	50	85	105	135	95	120
240'	----	----	----	----	----	----	50	90	110	140	100	125
250'	----	----	----	----	----	----	55	90	115	150	100	130

The above values are in lb/ft. This means if a value was 44 then you would apply 44 lbs. of pressure at the end of a 12" long wrench handle. Multiply these values by 1.356 to convert to N/m (metric system value).

**These values are guidelines only and based on 48 lbs. per cubic foot material weight.**

Many factors such as condition of pulley lagging, belt type, cup size & spacing, dampness, etc. will effect the actual required tension for your leg. The "**ideal tension**" is the lowest tension at which the belt will not slip under normal operating conditions. It is imperative that there is proper feeding of the boot inlet for even cup fill. If side loading occurs this may cause uneven cup fill and can create material build up between the pulley and belt. This will make it harder to track the belt and adds excessive tension to head & boot components and belt.

The boot take-up should be checked often, especially with a new belt.

**NOTE:** Please contact factory if you encounter problems using these guidelines.

**NOTE:** Contact factory service personnel for torque values on double and triple leg models.

## SECTION 2 - ASSEMBLY AND INSTALLATION

### SAFETY DEVICES

Slowdown monitors, explosions panels, belt alignment monitors, and other safety interlock equipment may be part of your installation.

Each of these should have specific instructions regarding installation and use and are not cover in this manual.

### LADDER, CAGE & PLATFORMS

These items are covered in our Platform assembly manual. All ladder, cage, and platforms are shipped with an accompanied assembly manual. If you have a special designed platform a drawing and bill of materials will be included with the assembly manual.

If needed, please contact factory for drawings.

### EXPLOSION PANELS

In the event of the relief panel being blown off it is a must to replace with original mounting hardware

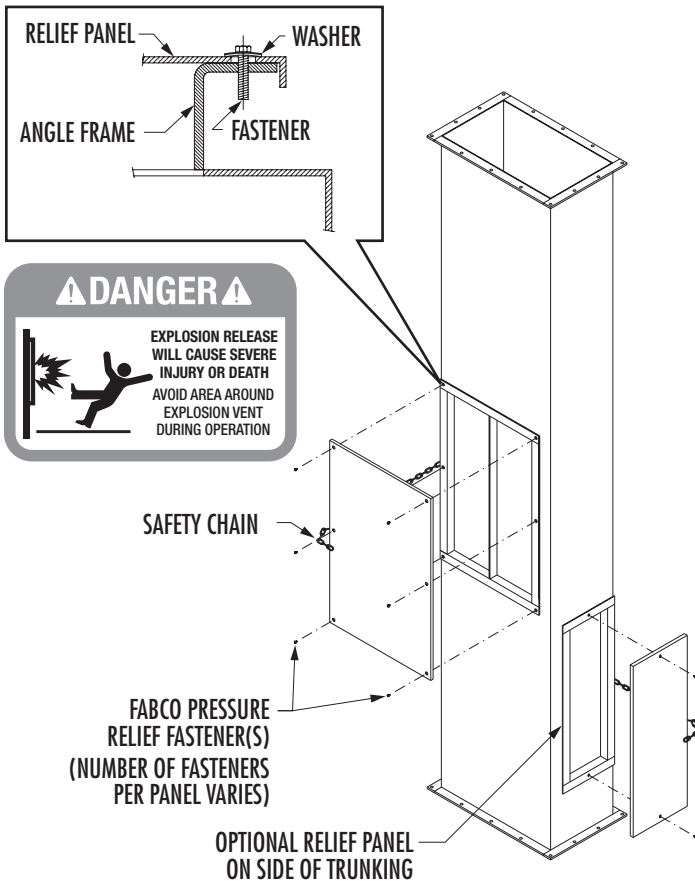

### MAINTENANCE

Drives and bearings should be lubricated per the manufacturer's instruction. A minimum of 10 hours running time after initial start up, and each 100 thereafter should be used as a guideline for checking and relubrication in the absence of specific instruction.

Other than as noted above, the bucket elevator requires very little repetitive maintenance. Instead, like the tire on a car, it should be checked often for signs of wear, unusual noises and changes in operating characteristics.

#### *Some things to look for are:*

- Improper belt centering.
- Damaged or missing cups.
- Boot shaft not rotating properly under load.
- Striking or rubbing noises in the trunking.
- Backlegging.
- Loose or missing housing bolts
- A lack of capacity.

If any of these conditions are observed they should be remedied immediately. Qualified personnel should follow the troubleshooting guide listed in the trouble shooting section on pages 17 and 18. Correct the situation using the procedures given in this manual.

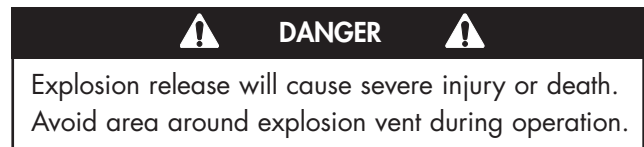





## SECTION 3 - TROUBLE SHOOTING

PROBLEM	CAUSE	REMEDY
Running noise In head	Cups rubbing on throat plate	Adjust throat wiper to an 1 /8" from the leading edge of a cup on the lap splice.
Running noise in boot	Foreign object in boot housing Shaft rubbing UHMW dust seal	Remove clean out doors in boot and inspect Lubricate dust seal (WD-40 or grease)
Running noise in trunking	Cups hitting on the inside of trunking	Tension leg belt Check leg for plumb Check leg for bow in trunking
Leg belt running to one side of boot pulley	Improper adjustment	Adjust boot takeups to center belt
	Bad bearing	Replace bearing
	Product build up on pulley face	Clean pulley and check crown
	Grain flow pushing cups	Make a BAFFLE to direct grain into cups straight
Leg belt running to one side of head pulley	Not enough or no crown	Replace pulley or install new (Craft type lagging)
	Head shaft not level	Shim bearings (raise to side belt is running)
	If leg has a back leg roll	Adjust tracking with vertical movement of bearing
	Bad bearing (shaft settles)	Replace bearing
Backlegging on the "downside"	Product going past throat plate	Throat plate needs adjustment or replacement
	Improper speed	Check literature for min. and max. speed requirements
	Foreign object lodged in discharge not allowing the material to enter discharge	Remove inspection door and inspect
	Late discharge from cup	Check for proper venting of cups
Material noise in the upleg is normal for the first twenty feet up from the boot section (Don't confuse this with Backlegging)	A certain amount of grain displacement is normal due to material striking the cup edges causing it to be thrown up towards the inspection section and falling back down.  Also the material starts to level off in the cups thus causing material noise in the upleg.	

PROBLEM	CAUSE	REMEDY
Low capacity	Cups not full (product should cover cup bolt)	Check feeding device
		Upside inlet too low or boot pulley to high. Try lowering boot pulley to see if cup fill is improved.
		Belt speed too high or cup spacing too close (not allowing material to enter cup)
	Air locked (usually only problem with light fluffy material)	Perforated cups may be required for light, fluffy material.
		This problem is caused by the leg acting as an air pump, creating pressure in the leg and not allowing the material to enter the boot. Proper venting and / or suction will be required.
	Inadequate discharge spouting	This can be checked by observing the throat under full loading. If it fills with material up to the throat plate, it is an indication the spouting is poorly designed and must be corrected before full capacity can be realized.
	Belt slippage	This is a dangerous condition and must be corrected immediately.  A fire in the head section may result or the leg may plug. It is caused by improper belt tension or worn or missing head pulley lagging.
	Wrong cups or cup spacing	Check to see that the correct cup type, size and spacing is used according to the specifications given in the bill of materials.
	Low horsepower	If the belt speed decreases under load for reasons other than slippage, check all drive components including reducer ratio, sprocket or sheave diameters, and motor HP and RPM against the bill of materials. Readings for voltage and current draw under load will be helpful in assessing the problem.
		A poorly fed or overfed boot, or feeding on the downside will require additional horsepower.
Material build-up in cups	Wet or stick surface materials that has been allowed to build up on the inside surface of the cup, can substantially reduce the volume of the cup. Recirculating abrasive material in the leg every so often may help keep the cups clean.	



**Please contact our service department for help with any concerns or questions about your Bucket Elevator.**

**SCHLAGEL**

491 North Emerson Street • Cambridge MN 55008-1316 U.S.A.  
Toll Free (800) 328-8002      FAX (763) 689-5310  
Local / International (763) 689-5991    EMAIL sales@schlagel.com

**[www.schlagel.com](http://www.schlagel.com)**

©2016 Schlagel Inc. Rev. D 05/16 Printed in U.S.A.